

## **Human-To-Human Interface for Paralyzed Person**

Karan Ramteke<sup>1</sup>, Shruti Gharad<sup>2</sup>, Shivani Bilgaiyan<sup>3</sup>, Aakansha Ganvir<sup>4</sup>

*Department of Electronics & telecommunication, Jhulelal Institute Of Technology, Nagpur, India*

---

**Abstract:-** This project aims to develop a device that allows to provide movements into the paralyzed hand according to the movement in an active hand. The functionalities of the develop device include:

Four basic operations are:

1. Sensing of Neuro Signal.
2. Process a signal using medical device.
3. Discharging a signal into paralyzed hand.
4. Observing movements in paralyzed hand.

The developed device is very attractive in its shape and performance.

---

### **I. Introduction**

Neuroprosthetic has designing a machine that interfaces with living neurons to control a device or for sensory substitution. But what about muscles? If people has damage to their spinal nerves, the muscles themselves can be stimulated, and this line of research is called “functional electrical stimulation.”[2] For example, functional electrical stimulation can often be used to help someone stand up, or to improve walking by helping to swing a foot forward.[2]

With electrophysiology setup and electrical stimulation, the neuro pulses of human brain have been sensed by sensors and converted into electronic signals.[2]

The received electronic signals as mentioned above will be further converted in such a way that it can discharge the electric voltage to the paralysed person hands.[2]

### **II. Methodology**

With electrophysiology, the neuro signal of human brain are sensed by the sensors and then pick up the signals with the help of that sensor's from the working hand and after amplification of that signal, the amplified signal will fed to the another non-working hand(paralyzed hand).

In accordance with working hand, the paralyzed hand will perform movements.

With our electrophysiology setup we will learn exciting neuro science concepts first hand as your brain sends and electrical impulse to your arm's muscles, telling them to move, and when your muscles moves, this generates an even larger electrical signal.

We will take that electricity then further amplify it and inject it into the nerves controlling another paralyzed hand.

This will give us a direct education about the importance of electrophysiology. The paralyzed hand will obey your electrical commands and moves as same as the another hand.

### **III. Circuit Diagram**

The AD623N is an integrated single or dual supply instrumentation amplifier. It's required supply voltage from 3-12V.It's use to measure rail-to-rail output swing. Input voltage range extends 150uV for single supply. It's used in Biomedical instrumentation, Data Acquisition & Difference Amplifier. The output of instrumentation amplifier from AD623N is now fed as input to the Filter circuit that is Band Pass Filter.

The function of Band Pass Filter is to select the required range of frequencies. Band Pass filter will select the required frequency which is lies between 300-1200 Hz and also reduce the supply voltage. Therefore this give output of some voltage, then it again reduce supply voltage.

Now this supply is given to the Analog input of ARDUINO controller. Now ARDUINO is build by program which controls programmable switches, LED's, and Relay.

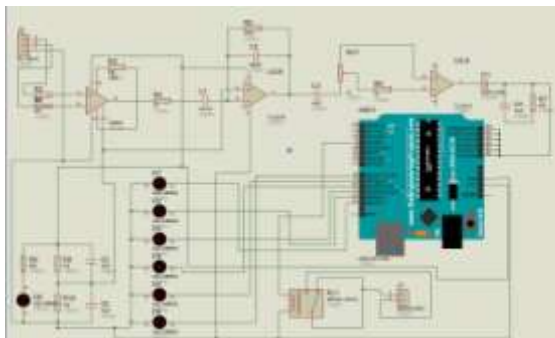

#### IV. Hardware Used

##### 1. Tens 250

TENS is most commonly used to delivered from small hand held battery powered devices. TENS device is a treatment technique is non invasive and has few side effects when compared with drug therapy. The most common complaint is allergic type skin reaction and this is almost always due to the material of the electrodes, the conductive gel or tape employed to hold the electrodes in place. Most TENS applications are now made using self adhesive, pre gelled electrodes which have several advantages including reduced cross infection risk, ease of application, lower allergy incidence rates and lower overall cost.[5]

Garment based electrodes becoming more widely available and for some patients provide an excellent method of application. Like the pre gelled electrodes they are supposed to be multi-use but for single patient i.e. should not be 'shared'. [5]

Digital TENS machines are becoming more widely available & extra features are emerging, though there remains little clinical evidence for enhanced efficacy at the present time. Some of these devices do offer pre-programmed and/or automated treatment settings.[5]

##### 2. ECG SENSORS:-

The electrocardiogram (ECG or EKG) is a diagnostic tool that is routinely used to assess the electrical and muscular functions of the heart.[3]

The electrocardiography (ECG) has grown a one of the most commonly used medical tests in modern medicine. Its utility in the diagnosis of a myriad of cardiac pathologies ranging from myocardial is chemia and infarction to syncope and palpitations has been invaluable to clinicians for decades.[3]



## **V. Conclusion**

We create a project for patient with paralysis. The user can use this device so easily. This device is portable device. EMG ELECTRODE sensor connected with a device. The EMG ELECTRODE sensor sense a signal from active hand of paralyzed person and discharge this signal with amplification and filter a signal into the paralyzed hand of a patient.

## **VI. Result**

We produce the movement into the paralyzed hand successfully. This project is beneficial in bio-medical field to reanimate the paralyzed people and in future this may be implemented by using wireless technique also.



## **References**

- [1]. [www.pololu.com/product/2191](http://www.pololu.com/product/2191)
- [2]. [Ieeexplore.ieee.org](http://Ieeexplore.ieee.org).
- [3]. [www.ECGSensor.com](http://www.ECGSensor.com)
- [4]. [www.alldatasheets.com](http://www.alldatasheets.com)
- [5]. <http://www.electrotherapy.org/assets/Downloads/TENS%20Jan%202016.pdf>
- [6]. <https://components101.com/microcontrollers/arduino-uno>